

# spec sheet



## jumbo silt trap

**300 LITRE CAPACITY**

The build-up of silt and dirt in your drainage system is a major problem particularly from hard standing areas. The jumbo silt trap is particularly effective at removing silt and sand before it enters the drainage system.

The Jumbos 2 stage patented process will store approximately 300 litre of silt or solids. Its the central hollow baffle makes the product very strong as well effectively separating hydrocarbons (oils and greases) that are flushed down into your drainage system. The silt and sand will drop to the base of the unit as they are heavier than water, there they are trapped behind the stepped baffle and combined with the hollow baffle this creates a designed flow path that any hydrocarbons that drop below the hollow baffle will follow.

It is extremely robust manufactured from Hdpe and lightweight at 23 kilos, so simple to install by a single person. All jumbo silt traps come with a 500mm invert and a pedestrian duty lockable access cover. With an option of either 110mm or 160mm en1401 inlets and outlets.

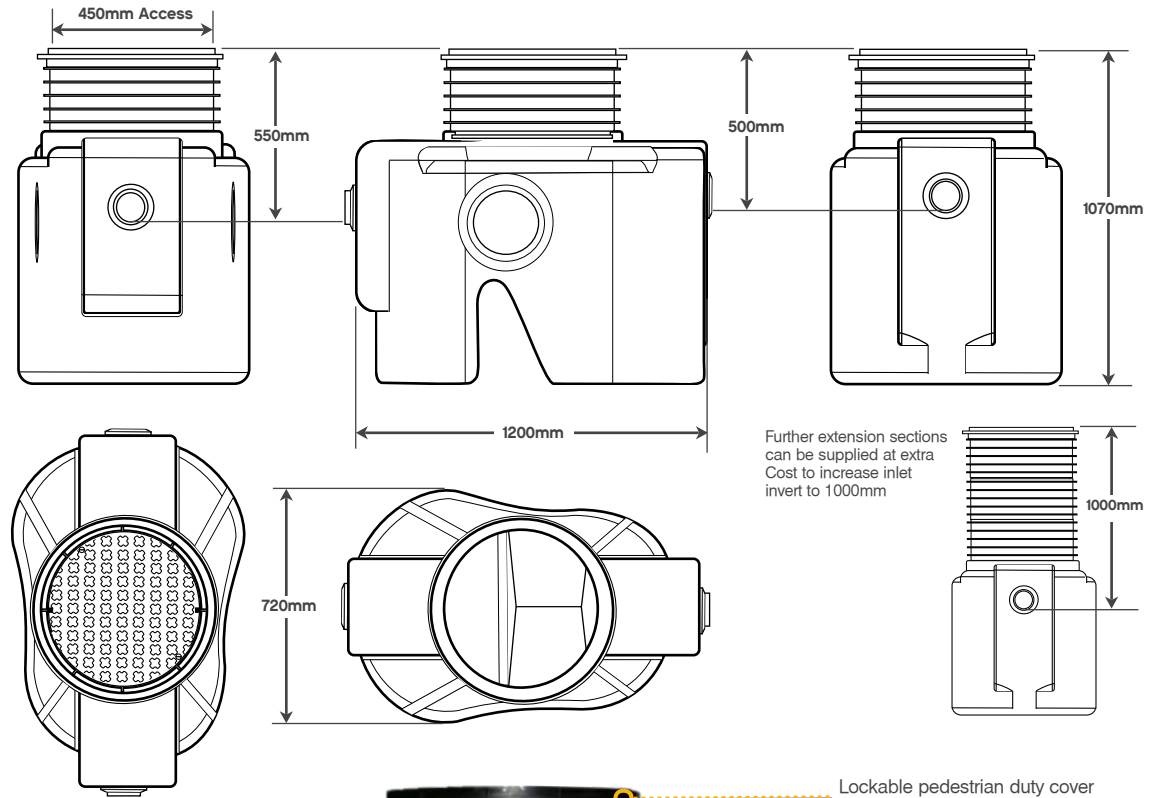

Tel. 0191 3545900  
Email: sales@turtleenviro.co.uk

[www.turtleenviro.co.uk](http://www.turtleenviro.co.uk)